

Surname		Other Names	
Centre Number		Candidate Number	
Candidate Signature			

Leave blank

General Certificate of Education
January 2006
Advanced Level Examination



PHYSICS (SPECIFICATION A)
Unit 4 Waves, Fields and Nuclear Energy

PA04

Section B

Friday 20 January 2006 9.00 am to 10.30 am

<p>For this paper you must have:</p> <ul style="list-style-type: none"> • a calculator • a pencil and ruler

Time allowed: The total time for Section A and Section B of this paper is 1 hour 30 minutes

Instructions

- Use blue or black ink or ball-point pen.
- Fill in the boxes at the top of this page.
- Answer **all** questions.
- Answer the questions in the spaces provided.
Show all your working.
- Do all rough work in this book. Cross through any work you do not want marked.

Information

- The maximum mark for this Section is 45.
- The marks for questions are shown in brackets.
- You are expected to use a calculator where appropriate.
- A *Data Sheet* is provided on pages 3 and 4 of Section A. You may wish to detach this perforated sheet at the start of the examination.
- You are reminded of the need for good English and clear presentation in your answers. Questions 3(b) and 4(a) should be answered in continuous prose. Quality of Written Communication will be assessed in these answers.

For Examiner's Use			
Number	Mark	Number	Mark
1			
2			
3			
4			
5			
Total (Column 1)		→	
Total (Column 2)		→	
Quality of Written Communication			
TOTAL			
Examiner's Initials			

Answer **all** questions.

You are advised to spend approximately **one hour** on this section.

- 1 (a) A spring, which hangs from a fixed support, extends by 40 mm when a mass of 0.25 kg is suspended from it.

- (i) Calculate the spring constant of the spring.

.....

.....

- (ii) An additional mass of 0.44 kg is then placed on the spring and the system is set into vertical oscillation. Show that the oscillation frequency is 1.5 Hz.

.....

.....

.....

.....

(4 marks)

- (b) With both masses still in place, the spring is now suspended from a horizontal support rod that can be made to oscillate vertically, as shown in **Figure 1**, with amplitude 30 mm at several different frequencies.

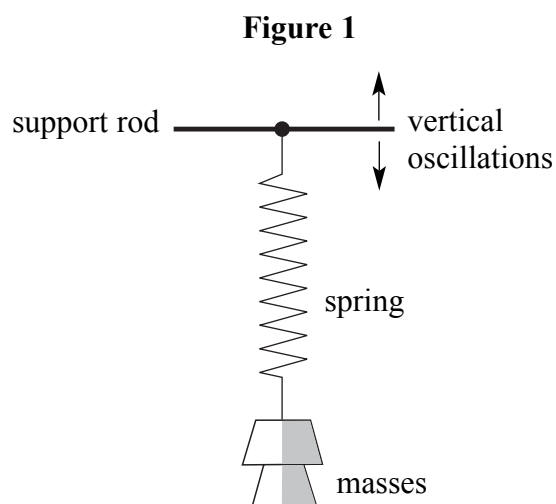

Describe fully, with reference to amplitude, frequency and phase, the motion of the masses suspended from the spring in each of the following cases.

- (i) The support rod oscillates at a frequency of 0.2 Hz.

.....

.....

.....

.....

.....

- (ii) The support rod oscillates at a frequency of 1.5 Hz.

.....

.....

.....

.....

.....

- (iii) The support rod oscillates at a frequency of 10 Hz.

.....

.....

.....

.....

.....

(6 marks)

10

Turn over ▶

2 A $680\ \mu\text{F}$ capacitor is charged fully from a $12\ \text{V}$ battery. At time $t=0$ the capacitor begins to discharge through a resistor. When $t=25\ \text{s}$ the energy remaining in the capacitor is one quarter of the energy it stored at $12\ \text{V}$.

(a) Determine the pd across the capacitor when $t=25\ \text{s}$.

.....
.....
.....
.....

(2 marks)

(b) (i) Show that the time constant of the discharge circuit is $36\ \text{s}$.

.....
.....
.....
.....
.....
.....

(ii) Calculate the resistance of the resistor.

.....
.....

(4 marks)

6

3 (a) Explain why, after a period of use, the fuel rods in a nuclear reactor become

(i) less effective for power production,

.....
.....
.....

(ii) more dangerous.

.....
.....
.....

(3 marks)

(b) Describe the stages in the handling and processing of spent fuel rods after they have been removed from a reactor, indicating how the active wastes are dealt with.

You may be awarded marks for the quality of written communication in your answer.

.....
.....
.....
.....
.....
.....
.....
.....
.....
.....
.....
.....
.....
.....
.....
.....
.....
.....
.....
.....
.....
.....
.....

(5 marks)

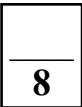

Turn over ▶

- 4 (a) Artificial satellites are used to monitor weather conditions on Earth, for surveillance and for communications. Such satellites may be placed in a *geo-synchronous* orbit or in a low polar orbit.

Describe the properties of the geo-synchronous orbit and the advantages it offers when a satellite is used for communications.

You may be awarded marks for the quality of written communication in your answer.

.....

.....

.....

.....

.....

.....

.....

.....

.....

.....

(3 marks)

- (b) A satellite of mass m travels at angular speed ω in a circular orbit at a height h above the surface of a planet of mass M and radius R .

- (i) Using these symbols, give an equation that relates the gravitational force on the satellite to the centripetal force.

.....

.....

.....

- (ii) Use your equation from part (b)(i) to show that the orbital period, T , of the satellite is given by

$$T^2 = \frac{4\pi^2(R+h)^3}{GM}$$

.....

.....

.....

- (iii) Explain why the period of a satellite in orbit around the Earth cannot be less than 85 minutes. Your answer should include a calculation to justify this value.

$$\text{mass of the Earth} = 6.00 \times 10^{24} \text{ kg}$$

$$\text{radius of the Earth} = 6.40 \times 10^6 \text{ m}$$

.....

.....

.....

.....

.....

.....

.....

(6 marks)

- (c) Describe and explain what happens to the speed of a satellite when it moves to an orbit that is closer to the Earth.

.....

.....

.....

.....

(2 marks)

11

Turn over for the next question

Turn over ▶

- 5 (a) An electron travels at a speed of $3.2 \times 10^7 \text{ m s}^{-1}$ in a horizontal path through a vacuum. The electron enters the uniform electric field between two parallel plates, 30 mm long and 15 mm apart, as shown in **Figure 2**. A potential difference of 1400 V is maintained across the plates, with the top plate having positive polarity. Assume that there is no electric field outside the shaded area.

Figure 2

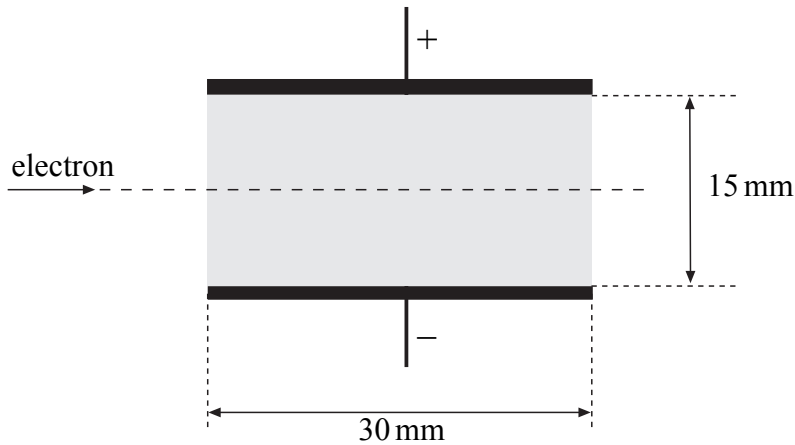

- (i) Show that the electric field strength between the plates is $9.3 \times 10^4 \text{ V m}^{-1}$.
-
-
- (ii) Calculate the time taken by the electron to pass through the electric field.
-
-
- (iii) Show that the acceleration of the electron whilst in the field is $1.6 \times 10^{16} \text{ m s}^{-2}$ and state the direction of this acceleration.
-
-
-
-

(5 marks)

(b) Determine the magnitude and direction of the velocity of the electron at the point where it leaves the field.

.....

.....

.....

.....

.....

.....

.....

.....

.....

.....

(3 marks)

8

Quality of Written Communication *(2 marks)*

2

END OF QUESTIONS

There are no questions printed on this page

There are no questions printed on this page

There are no questions printed on this page